

Industrial Power Solutions for Oil & Gas Fields in the Caspian Area

Hundreds of AC and DC UPS's have been supplied by Borri to the offshore and onshore plants in Kashagan and Karachaganak

■ Franco Fabbri, Franco Checcacci, Eugenio Mascagni - Borri SpA

The oil and gas business requires more and more high technology, both in equipment and in control functions. High technology means high investment and the increasing importance of continuous operation. Uninterrupted Power Systems (UPS) allow uninterrupted operation.

Borri's uninterrupted power systems cover the entire oil and gas logistics chain from exploration and drilling to distribution and retail. Its presence covers the main oil and gas flows around the world, on- or off-shore, IT or electrical systems. The company offers cost-effective solutions proven in the hardest of operating conditions. These solutions, based on AC and DC UPS's and batteries, are primarily designed to meet requirements for applications in the oil and gas, petrochemical, chemical and power generation industries. They are typically designed for production process plants, offshore rigs, refineries, pipelines, gas-gathering plants, LNG plants, storage plants.

These UPS systems ensure quality power supplies for pumps, control devices (Scada and DCS), fire-fighting systems, emergency lighting, air conditioning and other essential equipment.

The *Kashagan field* is the largest oil field discovered in the North Caspian Sea area. It is considered to be the most important oil discovery worldwide (**figure 1**). Kashagan's development represents a complex combination of coordinated offshore and onshore activities.

The *Karachaganak field* is one of the world's largest gas and condensate reservoirs.

Hundreds of AC and DC UPS's have been supplied by Borri to the offshore and onshore plants in Kashagan and Karachaganak.

The Kashagan field is the largest oilfield discovered in the North Caspian Sea area. It is considered to be the most important oil discovery worldwide. Kashagan's development represents a complex combination of coordinated offshore and onshore activities. The Karachaganak field is one of the world's largest gas and condensate reservoirs.

The oil and gas business requires more and more high technology, both in equipment and in control functions. High technology means high investment and the increasing importance of continuous operation. Here's where Borri industrial power solutions enters the stage with its comprehensive portfolio of uninterruptible power supply solutions.

Uninterrupted power allows uninterrupted operation. Hundreds of AC and DC UPS's have been supplied by Borri to the offshore and onshore plants in Kashagan and Karachaganak.

Kashagan field development, experimental programme, Kazakhstan

Kashagan, 80 km South-East of Atyrau, in the North Caspian Sea, is the largest oil field discovered over the last thirty years worldwide and extends over a surface of approximately 75 km by 45 km.

Its development represents one of the greatest challenges of the petroleum industry given the deep, high-pressure reservoir, the high sulphur content, the shallow waters that freeze in winter and wide temperature variations from -30 to +40 °C. The potential average production is of 1.2 million barrels/day.

The frame agreement

Borri was awarded the frame agreement for the

Borri SpA Profile

Borri was founded in 1932 in Bibbiena, Tuscany, Italy, specializing in the design and manufacturing of power electronic equipment for industrial applications. Since the sixties the main activity has been in the field of power conversion, both for domestic and export markets. Borri has a leading position in this particular market due to its expertise and the excellence of its continuous research and development in state-of-the-art equipment.

The company now has almost 80 years experience and thousands of Uninterruptible Power Systems (UPS) installed worldwide. A team of experts from R&D, sales-support, procurement, quality assurance, engineering, manufacturing, testing, expediting and after-sales and service will help the customers to choose the best solution for their applications.

The company integrates a full line of AC and DC power systems, power conversion products, power management software, remote monitoring, turnkey integration services and site support. It offers service on every step of installation projects from detailed design to a full installation.

Borri organisation can support Engineering and Procurement Companies (EPC) offices and customers during the sales, post order, after sales process. The company also provides a full range of globally available maintenance services that can be used independently or packaged into a maintenance agreement adjusted to a client company's particular situation.

provision of AC and DC UPS and batteries, for both offshore and onshore facilities for the Kashagan Experimental Programme. The project, started in 2005, is still in progress.

The end user of the provision is Agip Kazakhstan North Caspian Operating Company (Agip KCO), which is the operator (in 2009 it has been changed into NCOC) on behalf of the consortium comprising Eni, Shell, Total, ExxonMobil, KazMunayGas, ConocoPhillips and Inpex.

The contractors include Saipem, Aker Solutions, Bateman-Litwin, Consafe Mc Nulty, SBM Siemens, GE Nuovo Pignone, Tekfen, Renco, Rosetti Marino, Montazspetsstroy (MSS), ABB, Punji Lloyd, Petrofac.

The Kashagan Project consists of two developments: Offshore Complex and Onshore Complex.

Offshore Complex: artificial islands in the Caspian Sea

As part of the experimental programme and in support of drilling operations, Agip KCO has already constructed a number of rock structures that became

known as "artificial" or "drilling" islands.

In total, four drilling islands, Island A and Island D for Kashagan and two separate islands for Aktote and Kairan, have been built.

More artificial islands will be built as the project progresses and will be linked between themselves and onshore operations by pipelines.

Onshore Complex: Karabatan onshore processing facility

Agip KCO operations continue onshore, 35 km North-East of Atyrau. The works started in 2002.

When constructed, the onshore processing facility will receive oil and gas delivered from offshore in order to produce export quality oil and gas for further sale, as well as fuel gas for use at the Agip KCO onshore and offshore facilities.

Solutions delivered

The development will comprise a combination of both offshore and onshore processing facilities. The offshore production facilities will be tied to the onshore oil and gas processing and storage facilities to be located in a "greenfield" location approx 35 km North East of Atyrau.

The experimental programme is to be developed in three "tranches", sequenced, with intervals of six months between tranches 1 & 2 and two years between tranches 2 & 3:

the *off shore plants* include various barges (raw gas injection, flash gas compressor, living quarters, power generation etc.) assembled in different construction sites and then moved to the Caspian Sea;

the *on shore plants* (power plant, substations, oil & gas, sulphur treatment etc.) is located in Karabatan.

The potential average production amounts to 1.2

Fig. 1 – The Kashagan field is the largest oil field discovered in the North Caspian Sea area; it is considered to be the most important oil discovery worldwide

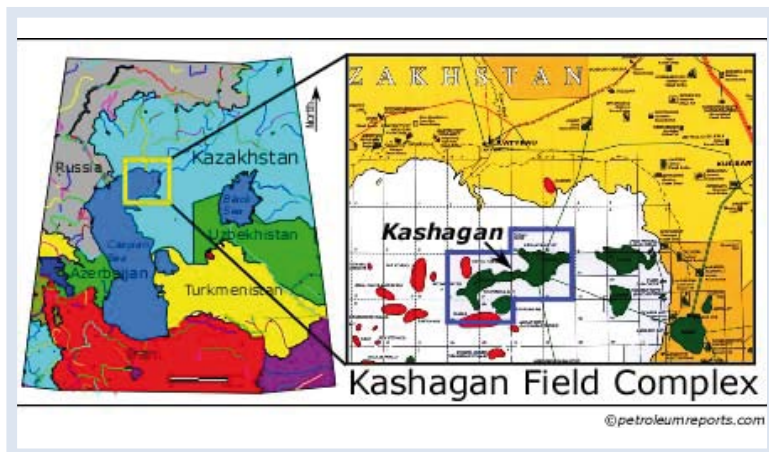

Project team, international management and local content

A dedicated project team has been assigned to support the customers during the job stages, including management and controlling of sales, engineering, quality, HSE (Health Safety Environmental) & certification, documentation, testing, shipping and service.

In fact, in Borri, as the order is received, a project-oriented team is in charge of the job. The project management covers all the job phases:

- technical and economical proposal;
- system engineering;
- project documentation;
- expediting and inspections during manufacturing;
- witness tests;
- worldwide supervision for commissioning and start up (engineer for off-shore service activities, licence available).

Borri can rely on its *international organisation*, based on several subsidiaries and widespread partnerships, in order to manage multinational projects, where the players, such as consultants, EPC companies and end-users, are located in different countries.

For Borri, *local content* means the development of local skills and know-how transfer, strengthen local manpower and entrepreneurship through its business. Even in Kazakhstan a local partnership to perform primarily service activities, such as start-up, commissioning and maintenance, provides considerable social benefits to the host country, in terms of investments, employment, development of subcontractors and other factors.

UPS systems supplied by Borri

AC and DC UPS systems are primarily designed to meet requirements for applications in the oil & gas, petrochemical, chemical and power generation industries.

They are typically designed for production process plants, refineries, pipelines, gas-gathering plants, LNG plants, storage plants. They suits to the basic concepts of reliability, robustness and durability, since these industrial products are commonly requested to operate under the most severe environmental conditions.

UPS systems ensure quality power supplies for pumps, control devices, fire-fighting systems, emergency lighting, air conditioning and other essential equipment.

Borri daily work is to deliver *customised tailor-made solutions*, designed to meet any specific application requirement.

These systems are designed to meet an *industrial product concept*, which includes IP41 protection

degrees, true front access to all of the components, special painting methods, flame retardant halogen free cables and colour-code identification of internal cables. Acting as an interface between the mains and sensitive applications, UPS's supply the load with continuous, high quality electrical power regardless of the status of the mains. UPSs deliver a dependable supply voltage free from all mains disturbances, within tolerances compatible with the requirements of sensitive electronic devices. UPS can also provide this dependable voltage independently by means of a power source (battery) which is generally sufficient to ensure the safety of individuals and the installation.

Borri supplies *static power supplies*, based on silicon devices, including high frequency controlled IGBT switches. The machine digital control can rely on very advanced microprocessors (**figure 3**).

The UPSs can be supplemented with additional features: an automatic static by-pass in the case of UPS overload or fault, a mechanical maintenance by-pass enabling the UPS to be completely isolated, as well as various options for signalling and maintenance. It is possible to combine more than one UPS in parallel to increase the reliability of the supply by providing one redundant unit (**figure 4**).

As above mentioned, the supplies are made up of DC UPS (rectifier and charger), single phase output AC UPS and three phase output AC UPS.

- DC UPS: RTB model
400 V AC, 3 ph, 50 Hz input, 110 V DC output 100 to 500 A (available up to 2000A), in dual configuration for redundancy with integrated 110 V DC distribution panel at a fine regulated voltage tanks to drop cells stabiliser, which prevent the variable battery voltage from feeding directly the loads.

- AC UPS: E2001 model
400 V AC, 3 ph, 50 Hz input, 230 V AC, 1 ph, 50 Hz output, 110/220/400 V DC battery voltage, ranging 5 to 200 kVA in single and dual configuration for redundancy with bypass isolation transformer and integrated 230 V AC distribution panels (**figure 5-6**).

- AC UPS: E3001 model
400 V AC, 3 ph, 50 Hz input, 400 V AC, 3 ph, 50 Hz output, 400 V DC battery voltage in dual configuration for redundancy with bypass isolation transformer and integrated 400Vac distribution panels comprising 400 V AC drive systems for HVAC (Heat Ventilation Air Conditioning) supply.

- Batteries
- Saft NiCd with gas recombination units, SBH/SBM/SBL model for on-shore plants, 2-8 hours autonomy time and capacity up to 1450 Ah.

Fig. 3 – UPS principles

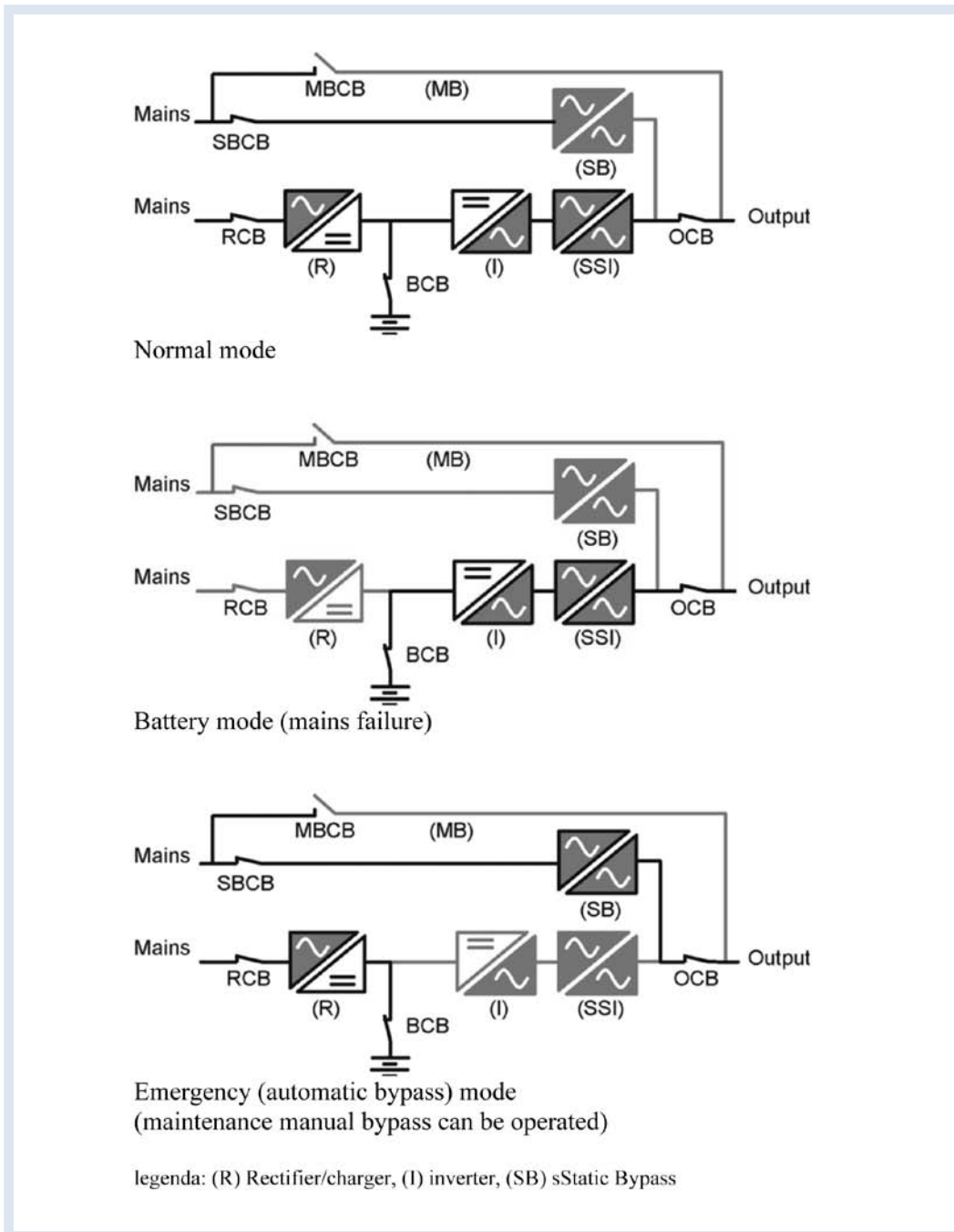

- Fiamm VRLA Gel type, SMG model for off shore plants, 2–8 hours autonomy time and capacity up to 3000 Ah.

The batteries are disconnected via wall mounted Eexd IIC T3 battery breaker box with 24 V ESD circuit.

- Battery discharger

Reverse operation of the rectifier/charger to automatically discharge battery into ac mains is a unique feature. The battery is discharged back into the mains, with:

- constant current;
- power current;
- individual profil.

This feature is specifically designed in order to fully test the battery, to simulate the load according to a typical

load profiles and to recover energy, saving money and without using special and costly load banks.

User interface and remote monitoring

Borri UPS systems are supplied with user interface and remote monitoring solutions for continuous real time monitoring and performance analysis of UPS and other power equipment. To meet the end users needs looking for tailor-made solutions, the units are equipped with front display with mimic and led's, lamps and meters which allow a local monitoring. In addition a remote monitoring is guaranteed via relay contacts and an advanced communication way based on the Modbus protocol.

A Modbus connectivity device fitted on each machine provides continuous, reliable and accurate remote



monitoring of a UPS system through a Building Management System (BMS) or Industrial Automation System (IAS).

The Modbus protocol, one of the most commonly used communication standard in industrial environment, defines a message structure that controllers will recognise and use, regardless of the type of networks over which they communicate.

The UPS connects to the network via RS-485 port. The port provides the means to integrate data from the UPS into the user-provided management system. Key power quality and UPS status information may be monitored in real-time to aid in the management of the UPS and notification of potential power problems. ■

Fig. 5-6 - 200kVA 230Vac UPS for main control building in Kashagan



Franco Fabbri is International Sales Manager in Borri SpA. He is graduate in Electronic Engineering at Florence University. He joined Borri company in the 90's as System Engineering Manager, after a previous

experience in Sirti SpA. He is the head of the Borri project team in charge of the Kazakhstan jobs.



Franco Checcacci is Project Engineer in Borri SpA. He is graduate in Electronic Engineering at Florence University. He joined Borri company in the 83's as test /service engineer, after a previous short experience in Olivetti

SpA. He is the senior Project Engineer of the Borri project team in charge of the Kazakhstan jobs.



Eugenio Mascagni is Product Marketing Manager, responsible for UPS products. In 2007 joined Borri SpA after several years inside the Eaton group. He is coordinator of the UPS Working Group, operating for

Assoautomazione of Anie (Italian Association of Electric Companies) and member of UPS committee at CEI (Comitato Elettrotecnico Italiano). In the 90's he develops his expertise in power electronics as R&D manager. He is graduate in Electronic Engineering at "La Sapienza" Rome University.